

INSTALLATION INSTRUCTIONS

DESCRIPTION: Folding Clutch Lever Kit
PART NUMBER 2GB-H39B0-V0
MODEL: YZ250FX, WR250F, WR450F



⚠ WARNING

Please read and understand these instructions completely before installation to avoid possible injury, or damage to the accessory or vehicle.

IMPORTANT: YZ models are for closed-course competition only regardless of modification. YZ models do not meet federal or state emission standards for recreational off-road use.

NOTICE:

This installation requires the Owner's Service Manual for the model and a torque wrench. It should be performed by an authorized Yamaha dealer or other qualified technician.

WARRANTY INFORMATION:

Genuine Yamaha GYTR accessories for YZ and WR models are covered by a 30-day limited warranty against defects in material or workmanship. Labor for replacement of defective components is not covered. See your Yamaha dealer for a copy of the limited warranty statement.

DEALER OR INSTALLER:

These instructions contain important information for future reference and *must* be given to the customer.

PARTS LIST:

Item	Part Number	Description	Qty
--	2GB-H39B0-V0	Folding Clutch Lever Kit	--
①	*	Clutch Lever Assembly	1

*Part supplied with kit and not available separately

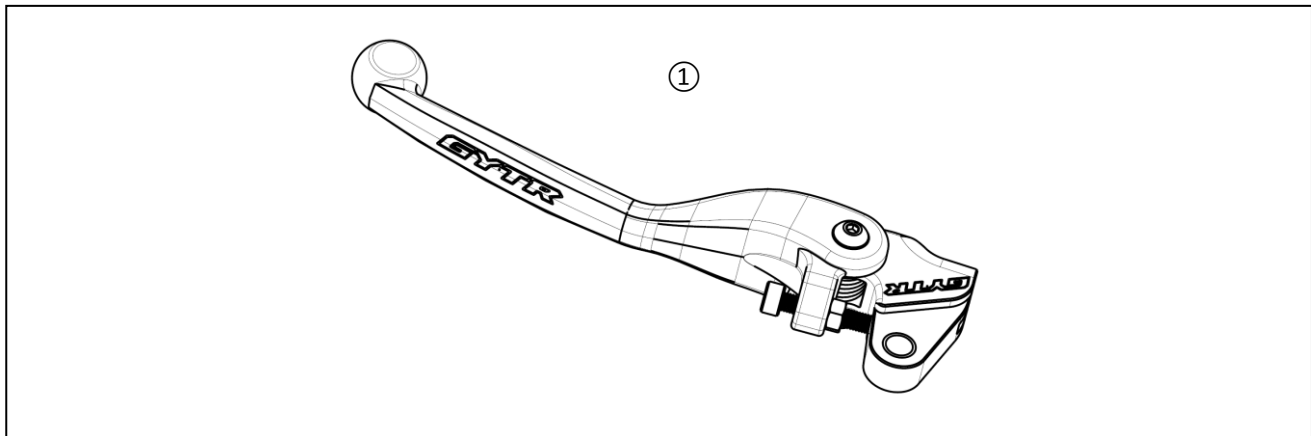

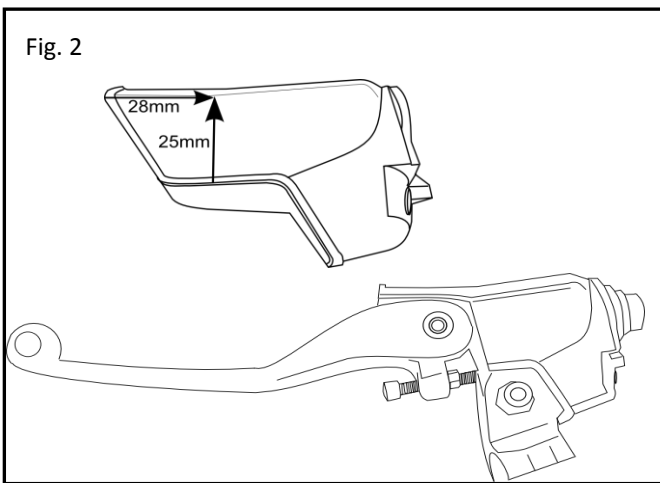
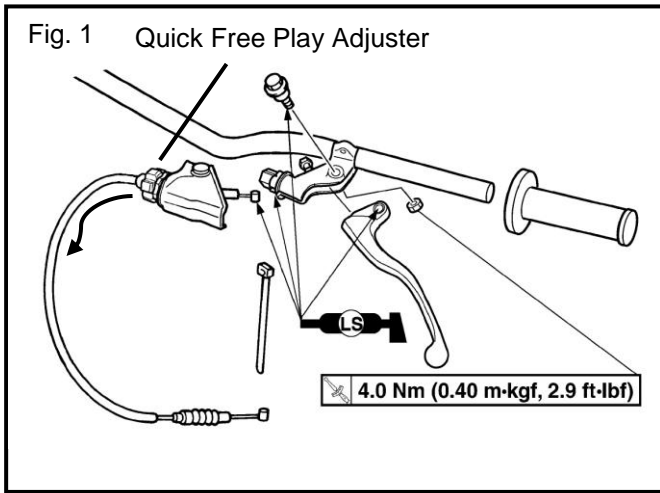

PREPARATION:

1. If your model is equipped with one, turn the gas petcock to the "Off" position.
2. Place motorcycle on a secure bike stand.

INSTALLATION:

1. Loosen the cable free play adjusters.
2. Remove the stock clutch lever off the perch by removing the 6mm locknut and then the pivot bolt. Place the bolt and nut to the side as they will be re-used. (Fig.1)
3. Clean inside the clutch perch prior to installation of your new clutch lever.
4. Slide the Quick Free Play Adjuster away from the perch along the cable (Fig.1)
5. Remove the stock rubber lever cover from the cable. Mark lines 28mm from the left edge and 25mm from the base on top and bottom as shown in Fig. 2. Use scissors or a razor knife to remove material from the cover. The top and bottom of the lever should be exposed, but the front still covered by the remaining rubber.
6. Install the modified lever cover back into position on the clutch cable. Slide the Quick Free Play Adjuster back onto the clutch perch.
7. Put a light coat of Yamalube[®] Race Grease (p/n ACC-RACEG-RE-AS) or lithium-soap (LS) based grease on the areas indicated in the Owner's Service Manual and in Fig.1.
8. Insert the end of the clutch cable into the new clutch lever, and place the lever into the clutch perch so that the hole in the lever lines up with the holes in the perch.
9. Place the stock bolt through the holes and thread into the perch. Now thread the stock M6 lock nut onto the bolt and tighten to 4 Nm (0.40 m·kgf, 2.9 ft·lbf). It should be snug without binding the clutch in the perch.
10. Refer to your Owner's Service Manual for the clutch lever position and free play adjustment procedures. **TIP:** The new lever has the position adjuster on the opposite side from stock, but the procedure is the same.

MAINTENANCE:

Periodically disassemble and clean components . Reassemble with a light coating of Yamalube Race Grease on all points of movement. Periodically check and tighten the bolt to specification.

CARE AND CLEANING:

Clean using a soft cloth with soap and water.

CUSTOMER SERVICE:

For further information see your Yamaha dealer.